

# **THE PRO DRAWING COLLECTION**

**Basic info per artist**

**PART 1**

## Nr. 1 Hans Hinterreiter

## Spain/Switzerland

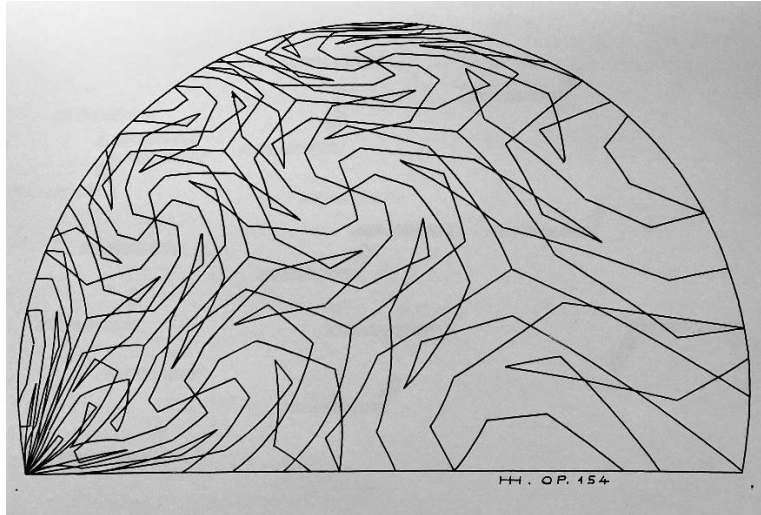

### Basic Info

Name: Hans Hinterreiter  
Profession: studied architecture, became a painter and art theorist  
Dates of life: 28 January, 1902, Winterthur – 15 September 1989, Ibiza  
Country of Origin: Switzerland  
Lived: Ibiza, Spain

Website: [www.hinterreiter-stiftung.ch](http://www.hinterreiter-stiftung.ch)  
[www.moma.org/artists/2661-hans-hinterreiter](http://www.moma.org/artists/2661-hans-hinterreiter)

### Description work in PRO Drawing Collection

Title: OP. 154  
Materials: ink on transparent paper  
Sizes: c. H32.5 x W45.5 cm - H12¾ x W 18 inches  
Remarks: originally inspired by a visit to the Alhambra, Spain, Hinterreiter built on the color and form theories of Wilhelm Oswald, perfecting the last in a very detailed and structured system of shapes and compositions – one may see his artistic research as a precursor to digital art. Both Hinterreiter works were provided by Dr. István Schlégl, the gallerist who represented Hinterreiter, promoting his works internationally, including an exhibition at MoMA New York. Dr. István Schlégl regularly supported the PRO Foundation's activities.  
Signed: bottom right

(no number, extra)

Hans Hinterreiter

Spain/Switzerland

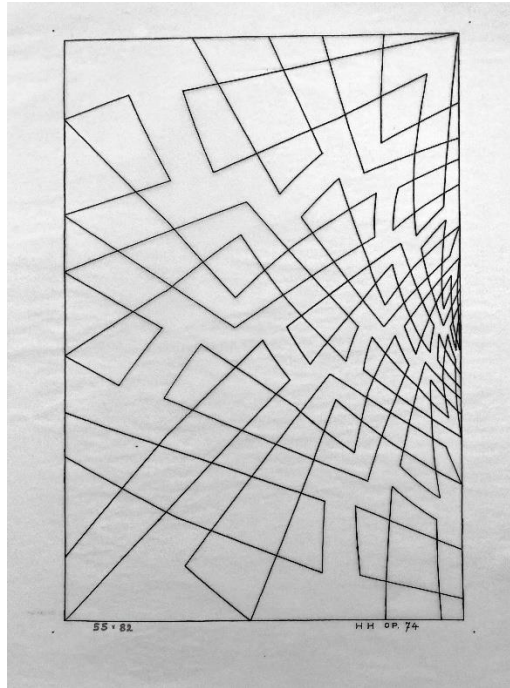

#### Basic Info

Name: Hans Hinterreiter  
Profession: studied architecture, became a painter and art theorist  
Dates of life: 28 January, 1902, Winterthur – 15 September 1989, Ibiza  
Country of Origin: Switzerland  
Lived: Ibiza, Spain

Website: [www.hinterreiter-stiftung.ch](http://www.hinterreiter-stiftung.ch)

#### Description work in PRO Drawing Collection

Title: OP. 74  
Materials: ink on transparent paper  
Sizes: c. H45.5 x W32.5 cm - H18 x 12¾ inches  
Remarks: originally inspired by a visit to the Alhambra, Spain, Hinterreiter built on the color and form theories of Wilhelm Oswald, perfecting the last in a very detailed and structured system of shapes and compositions – one may see his artistic research as a precursor to digital art. Both Hinterreiter works were provided by Dr. István Schlégl, the gallerist who represented Hinterreiter, promoting his works internationally, including an exhibition at MoMA New York. Dr. István Schlégl regularly supported the PRO Foundation's activities.

Signed: bottom right

## Nr. 2 Wim Smits the Netherlands

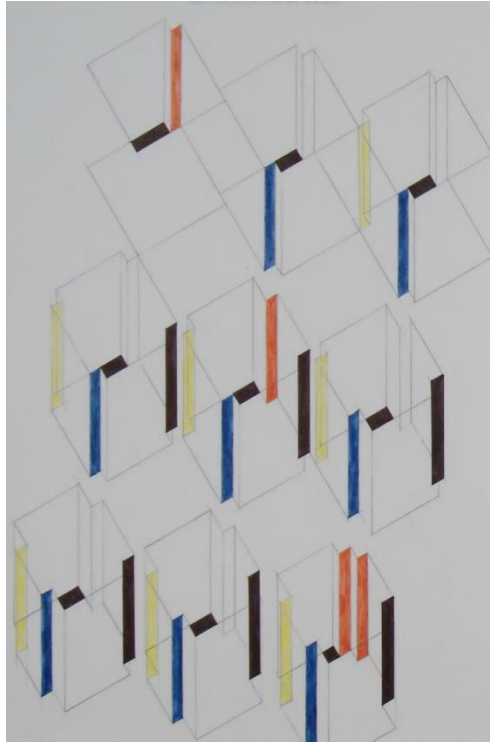

### Basic Info

Name: Wim Smits  
Profession: artist, designer  
Dates of life: 1922 - 2012  
Country of Origin: the Netherlands  
Lived:

Website: <https://www.st-ives.net/selected-art/smits/cv/index.htm>

### Description work in PRO Drawing Collection

Title: Analytical System Variations  
Materials: pencil and water color  
Sizes: H29.7 x W21 cm - c H11.7 x W8.3 inches  
Remarks:  
Signed: top center

### Nr. 3 Shizuko Yoshikawa Japan/Switzerland

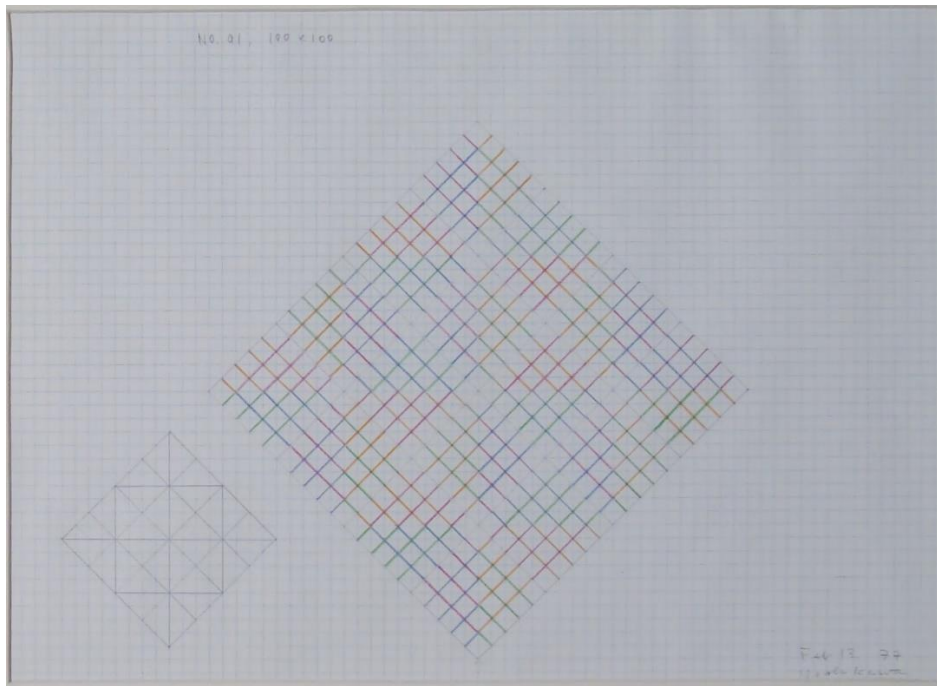

#### Basic Info

Name: Shizuko Yoshikawa  
Profession: artist, designer  
Dates of life: 8<sup>th</sup> January 1934 – 27<sup>th</sup> March 2019  
Country of Origin: Japan  
Lived: Switzerland  
Website: [syjmb.foundation/en/shizuko-yoshikawa/](http://syjmb.foundation/en/shizuko-yoshikawa/)

#### Description work in PRO Drawing Collection

Title: Feb. 13 1977, No. 01 (design for a painting 100 x 100 cm),  
Materials: pencil  
Sizes: H21 x W29.7 cm - c H 8.3 x W11.7 inches  
Remarks: Yoshikawa was a prominent painter in Zürich, Switzerland, and married to the acclaimed designer Josef Müller-Brockmann.  
Signed: bottom right

## Nr. 4 Alberto Zilocchi

Italy

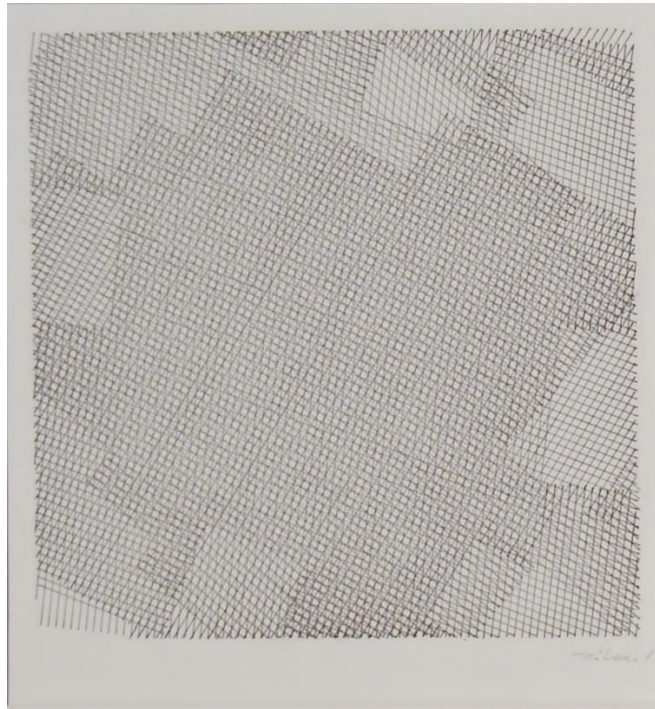

### Basic Info

Name: Alberto Zilocchi  
Profession: artist  
Dates of life: Bergamo 1931 - 1991  
Country of Origin: Italy  
Lived:

Website: [archivioalbertozilocchi.com/](http://archivioalbertozilocchi.com/)  
[www.spaziotestoni.it/en/alberto-Zilocchi/](http://www.spaziotestoni.it/en/alberto-Zilocchi/)

### Description work in PRO Drawing Collection

Title: no title  
Materials: pencil, ink on paper  
Sizes: H19 x W18 cm - H7½ x W7 inches  
Remarks:  
Signed: bottom right

## Nr. 5 Elizabeth Willmott Canada

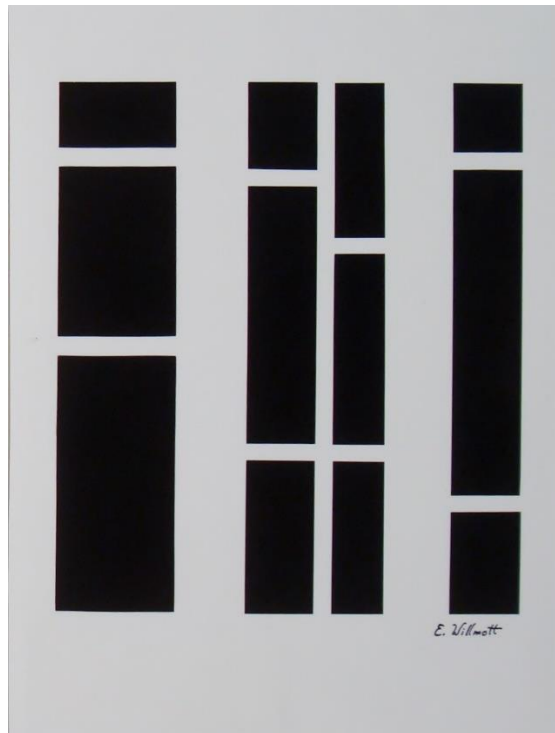

### Basic Info

Name: Elizabeth Willmott  
Profession: artist and author  
Dates of life: 1928 -  
Country of Origin: Canada  
Lived:

Website: [collection.thegoldfarbgallery.ca/personality/elizabeth-willmott/29848](http://collection.thegoldfarbgallery.ca/personality/elizabeth-willmott/29848)

### Description work in PRO Drawing Collection

Title: no title  
Materials: ink/print on gloss paper  
Sizes: H29.7 x W21 cm - c H11.7 x W8.3 inches  
Remarks: Willmott belongs to a core of Canadian structuralist artists, frequently published in *The Structuralist*  
Signed: bottom right

**Nr. 6 Manfred Mohr**

**W-Germany/USA**



**Basic Info**

Name: Manfred Mohr  
Profession: artist  
Dates of life: 1938 -  
Country of Origin: Germany  
Lives: New York, USA

Website: [www.emohr.com/](http://www.emohr.com/)

**Description work in PRO Drawing Collection**

Title: P.395.R, 1987  
Materials: plotter print  
Sizes: H21 x W29.7 cm - c H 8.3 x W11.7 inches  
Remarks: Mohr is internationally the most decorated pioneer of digital art;  
Signed: bottom right

## Nr. 7 Young Hyang Lee

## Korea/Germany

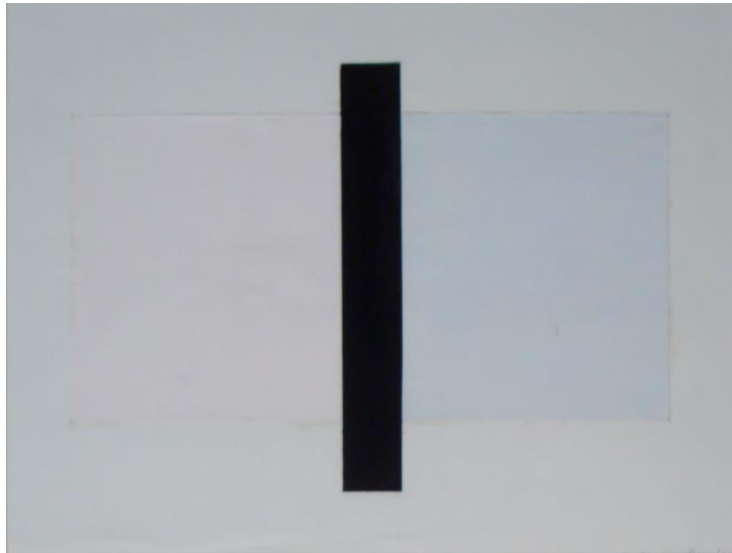

### Basic Info

Name: Young Hyang Lee  
Profession: artist  
Dates of life: 1952  
Country of Origin: South Korea  
Lives: Germany

Website: [www.facebook.com/aktuelle.kunst.saarland/posts/heads-legs-young-hyang-leeheute-zeigen-wir-das-werk-von-young-hyang-lee-als-beit/934075035415129/](https://www.facebook.com/aktuelle.kunst.saarland/posts/heads-legs-young-hyang-leeheute-zeigen-wir-das-werk-von-young-hyang-lee-als-beit/934075035415129/)

### Description work in PRO Drawing Collection

Title: no title, 1987  
Materials: collage with paint and cut out papers  
Sizes: H25 x W34 cm - H9¾ x W13½ inches  
Remarks:  
Signed bottom right corner and dated Jan.'87

## Nr. 8 Albert Rubens

## Belgium

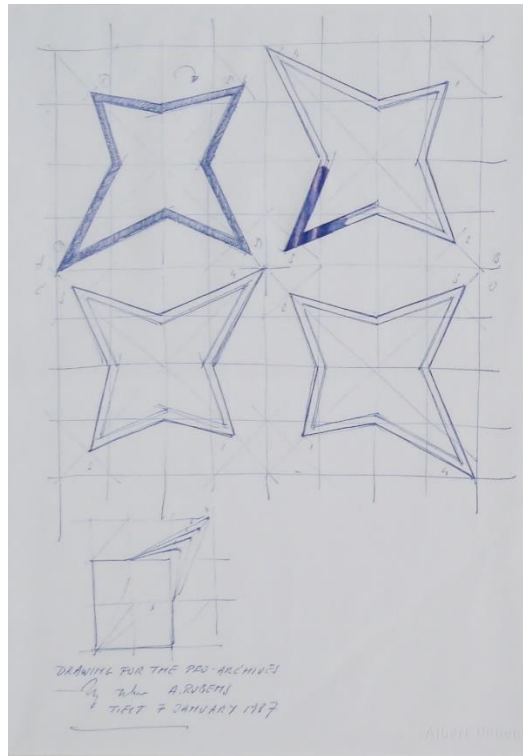

### Basic Info

Name: Albert Rubens  
Profession: artist  
Dates of life: 1944 -  
Country of Origin: Belgium  
Lives:

Website: [albertrubens.com](http://albertrubens.com)

### Description work in PRO Drawing Collection

Title: no title, 1987  
Materials: ball point pen on paper  
Sizes: H29.7 x W21 cm - c H11.7 x W8.3 inches  
Remarks: written on the work: "Drawing for the PRO archives"  
Signed: bottom left

**Nr. 10**

**Jean Jacques Bauweraerts**

**Belgium**



**Basic Info**

Name: Jean Jacques Bauweraerts

Profession: artist

Dates of life: 1953 -

Country of Origin: Belgium

Lives:

Website: [galeriequadri.com/artistes/jean-jacques-bauweraerts/](http://galeriequadri.com/artistes/jean-jacques-bauweraerts/)

Description work in PRO Drawing Collection

Title: no title, 1987

Materials: pencil, gouache on paper

Sizes: H32½ x W21 cm - H12¾ x W8.3 inches

Remarks: as a young artist Bauweraerts assisted Sol Lewitt for executing the famous wall drawings in Europe;

Signed: bottom right

**Nr. 11**      **Jürgen Blum/Kwiatkowski**      **Poland/Germany**

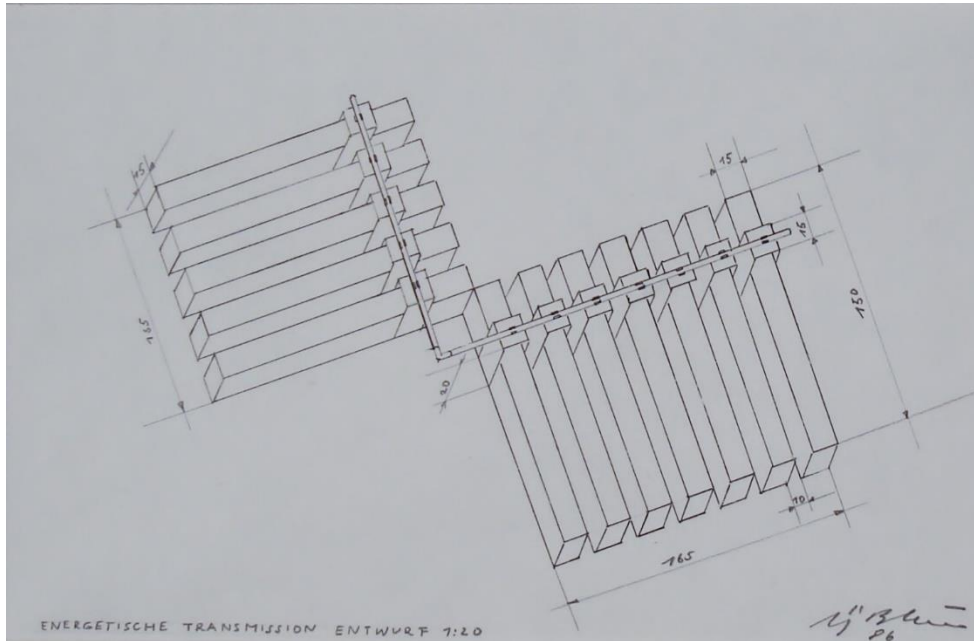

**Basic Info**

Name: (Gerhard) Jürgen Blum/Kwiatkowski  
Profession: artist, curator  
Dates of life: 22 October 1930, Eblag, Poland – 11<sup>th</sup> August 2015, Hühnfeld, Germany  
Country of Origin: Poland  
Lives:  
Website: [www.museum-modern.art/en/history/](http://www.museum-modern.art/en/history/)

Description work in PRO Drawing Collection

Title: Energetische Transmission Entwurf 1:20, 1986  
Materials: pencil, ink on paper  
Sizes: H21 x W29.7 cm - c H 8.3 x W11.7 inches  
Remarks: on the reverse side is a stamp of Kunststation Kleinsassen, the alternative art center he initiated in the vicinity of Fulda, Germany; for all activities of the PRO Foundation Blum-Kwiatkowski had a key role on contact with artists in Poland; he was a close friend, for instance, of Henryk Stazewski and Ryszard Winiarski;  
Signed: bottom right

**Nr.12 Dirk Verhaegen**

**Belgium**

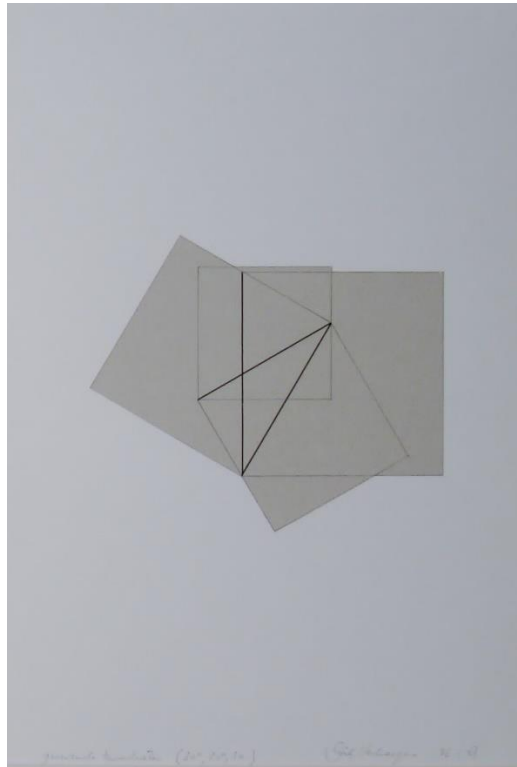

**Basic Info**

Name: Dirk Verhaegen  
Profession: artist  
Dates of life: 1950 -  
Country of Origin: Belgium  
Lives:

Website: [dirkverhaegenart.blogspot.com/2019/09/dirk-verhaegen.html](http://dirkverhaegenart.blogspot.com/2019/09/dirk-verhaegen.html)

**Description work in PRO Drawing Collection**

Title: groeiende kwadraten (30°, 30°, 30°) (growing squares)  
Materials: pencil, ink, collage of cut out grey paper mounted on paper  
Sizes: H29.7 x W21 cm - c H11.7 x W8.3 inches  
Remarks: + extra work on next page  
Signed: bottom right

(no number – extra) Dirk Verhaegen

Belgium

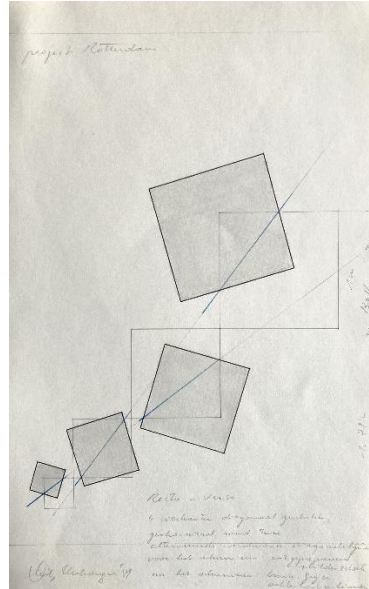

**Basic Info**

Name: Dirk Verhaegen  
Profession: artist  
Dates of life: 1950 -  
Country of Origin: Belgium  
Lives:

Website: [dirkverhaegenart.blogspot.com/2019/09/dirk-verhaegen.html](http://dirkverhaegenart.blogspot.com/2019/09/dirk-verhaegen.html)

Description work in PRO Drawing Collection

Title: Recto Verso, Projekt Rotterdam  
Materials: pencil on paper  
Sizes: H30 x W19 cm - c H11¼ x W7½ inches  
Remarks: design for artwork exhibited at a gallery during 3<sup>rd</sup> PRO Conference'89 in Rotterdam, the Netherlands  
Signed: bottom right

**Nr. 13      Hennie Lenders      The Netherlands**

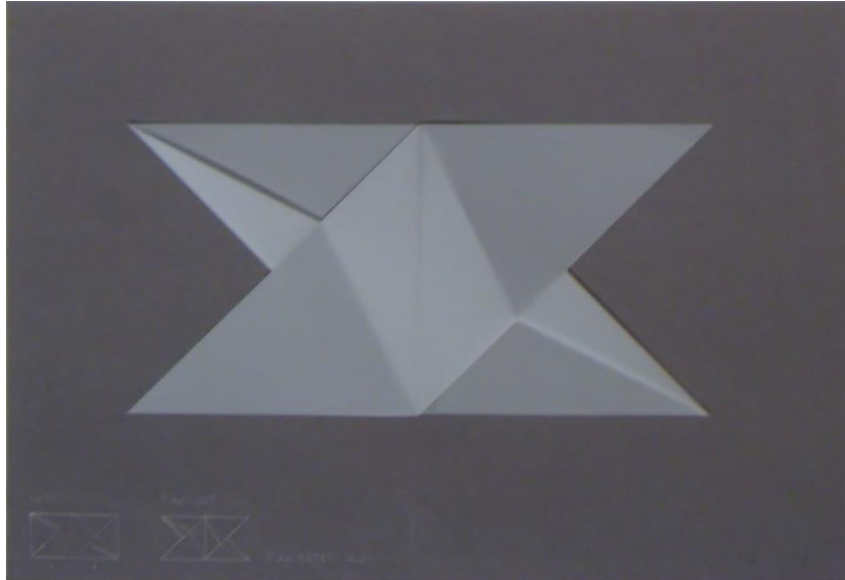

**Basic Info**

Name: Hennie Lenders  
Profession: artist  
Dates of life: 1952, Deurne -  
Country of Origin: the Netherlands  
Lives: Portugal

Website: [www.facebook.com/hennie.lenders/](http://www.facebook.com/hennie.lenders/)

**Description work in PRO Drawing Collection**

Title: no title  
Materials: collage with transparent folded paper  
Sizes: H21 x W29.7 cm - c H 8.3 x W11.7 inches  
Remarks:  
Signed: stamp with name and address on the reverse

**Nr. 14      Francisco Soto Mesa    Spain**

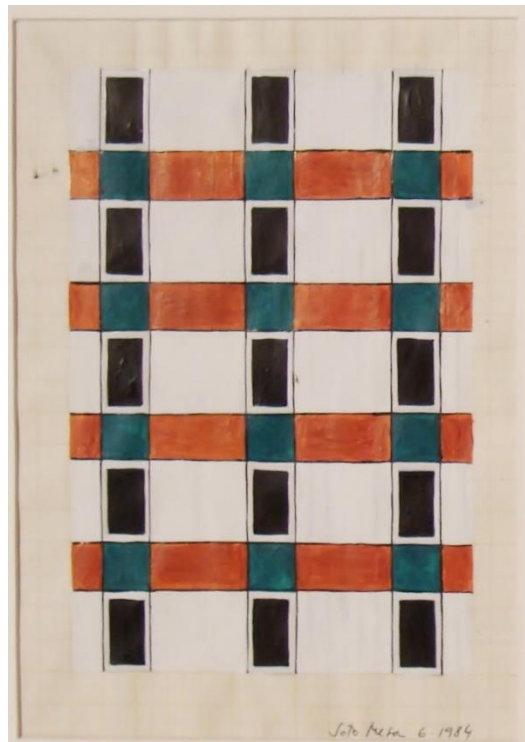

**Basic Info**

Name: Francisco Soto Mesa  
Profession: artist  
Dates of life: Madrid, 1946 -  
Country of Origin: Spain  
Lives:

Website: [www.franciscosotomesa.com/](http://www.franciscosotomesa.com/)

**Description work in PRO Drawing Collection**

Title: no title  
Materials: ink and gouache on paper, 1984  
Sizes: H23.7 x W17 cm - cH9 ¼ x W6¾ inches  
Remarks: a small ink smudge (top half left) by the artist himself  
the thin paper is a little wobbly caused by the application of paint  
Signed: bottom right

**Nr. 15**

**Charles Hess**

**USA**

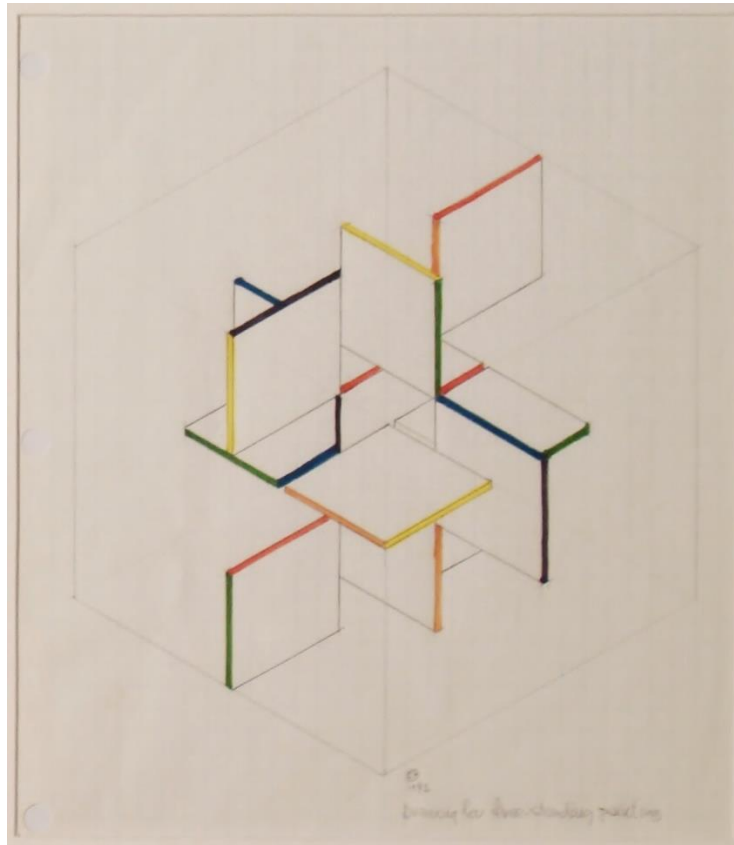

**Basic Info**

Name: Charles Hess  
Profession: artist  
Dates of life: Long Beach, California, 1921 - 1998  
Country of Origin: USA  
Lives:

Website: [www.aaa.si.edu/collections/charles-and-leta-english-hess-papers-9922](http://www.aaa.si.edu/collections/charles-and-leta-english-hess-papers-9922)  
See google

Description work in PRO Drawing Collection

Title: Drawing for free standing painting  
Materials: pencil and felt pen, 1982  
Sizes: H28 x W21½ cm - H11 x W8½ inches  
Remarks: his studio in the vicinity of Oakland and all works were destroyed during his lifetime by fire, likely causing this work to be (unfortunately) rather rare;  
Signed: bottom right

**Nr. 16      Roland Goeschl      Austria**

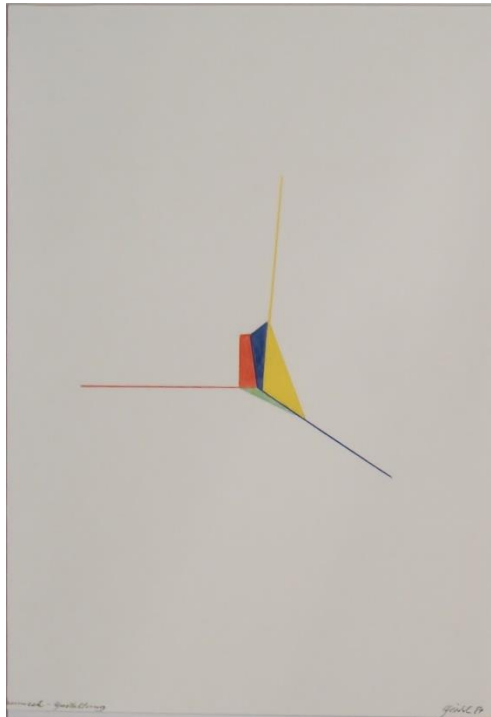

**Basic Info**

Name: Roland Goeschl  
Profession: artist, theorist  
Dates of life: 25<sup>th</sup> November 1932, Salzburg – 25<sup>th</sup> December 2016, Vienna  
Country of Origin: Austria  
Lives:

Website: [de.wikipedia.org/wiki/Roland\\_Goeschl](https://de.wikipedia.org/wiki/Roland_Goeschl)  
no English website to be found

**Description work in PRO Drawing Collection**

Title: Raumecke Gestaltung, 1987 (design for a corner)  
Materials: color pencil on paper  
Sizes: H31 x W28 cm - H12¼ x W11 inches  
Remarks: Goeschl was quite a prominent artist and teacher in Vienna, Austria  
Signed: bottom right

**Nr. 17      Heinz Gappmayr      Austria**

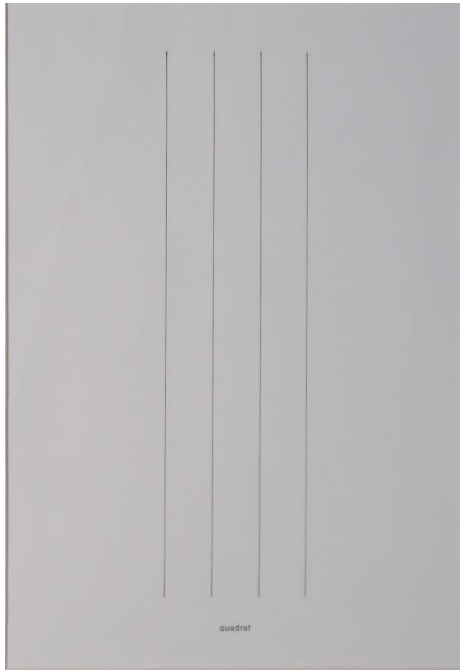

**Basic Info**

Name: Heinz Gappmayr  
Profession: artist  
Dates of life: 7<sup>th</sup> October 1925, Innsbruck, Austria – 20<sup>th</sup> April 2010, Innsbruck, Austria  
Country of Origin: Austria  
Lives:

Website: [galerie.vanderkoelen.de/Kuenstler/Heinz-Gappmayr/](http://galerie.vanderkoelen.de/Kuenstler/Heinz-Gappmayr/)

**Description work in PRO Drawing Collection**

Title: quadrat (square)  
Materials: ink on paper  
Sizes: H29.7 x W21 cm - c H11.7 x W8.3 inches  
Remarks: Gappmayr was a leading “concrete poet”, the work shows 4 lines and the word ‘square’  
The paper is not pristine and shows some light marks from the handling by the postman;  
Signed: on the reverse side

**Nr. 18**

**Nathan Cohen**

**UK**

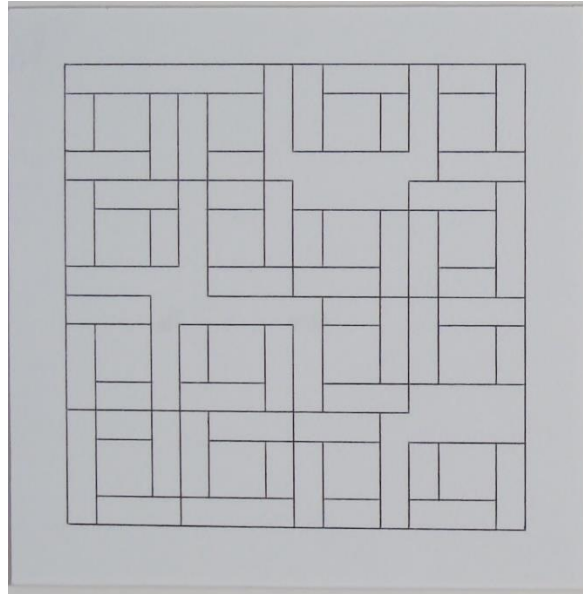

**Basic Info**

Name: Nathan Cohen

Profession: artist

Dates of life: 1962 -

Country of Origin: UK

Lives: London

Website: [www.nathancohen.co.uk/about](http://www.nathancohen.co.uk/about)

Description work in PRO Drawing Collection

Title: Rotation sunès, I/87, 1987

Materials: ink on paper

Sizes: H29.7 x W21 cm - c H11.7 x W8.3 inches

Remarks:

Signed: signed, titled and dated on the reverse side

**Nr. 19**      **Heinz Gruchot**      **W-Germany**



**Basic Info**

Name: Heinz Gruchot  
Profession: artist  
Dates of life: 11<sup>th</sup> October 1918, Wroclaw, Poland – 15<sup>th</sup> August 1994, Munich, Germany  
Country of Origin: Poland? Germany? (the borders in 1918 were different from today)  
Lives:  
  
Website: [de.wikipedia.org/wiki/Heinz\\_Gruchot](https://de.wikipedia.org/wiki/Heinz_Gruchot)  
no English website could be found

Description work in PRO Drawing Collection

Title: I,87  
Materials: collage of colored paper rectangles mounted on paper  
Sizes: H27 x W22½ cm - H10 5/8 x W9 inches  
Remarks:  
Signed: on the reverse side

**Nr. 20**

**Jaak Vuylsteke**

**Belgium**



**Basic Info**

Name: Jaak Vuylsteke  
Profession: artist  
Dates of life: 1951 -  
Country of Origin: Belgium  
Lives:

Website: [mx.pinterest.com/jaakvuylsteke/](https://mx.pinterest.com/jaakvuylsteke/)

Description work in PRO Drawing Collection

Title: A1B3, 1987  
Materials: pencil, ink on paper  
Sizes: H29.7 x W21 cm - c H11.7 x W8.3 inches  
Remarks:  
Signed: bottom left

**(no number – extra) Jaak Vuylsteke Belgium**

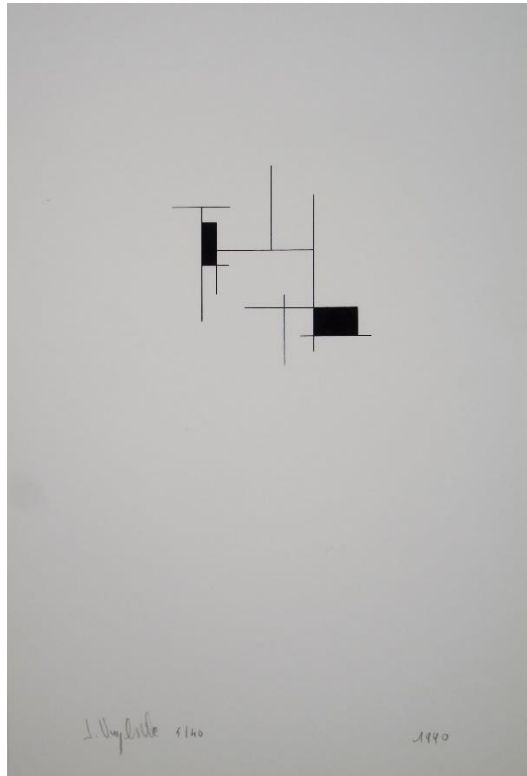

**Basic Info**

Name: Jaak Vuylsteke

Profession: artist

Dates of life: 1951 -

Country of Origin: Belgium

Lives:

Website: [mx.pinterest.com/jaakvuylsteke/](https://mx.pinterest.com/jaakvuylsteke/)

**Description work in PRO Drawing Collection**

Title: 5/40, 1990

Materials: screenprint

Sizes: H29.7 x W21 cm - c H11.7 x W8.3 inches

Remarks:

Signed: bottom left

**Nr. 21      Gottfried Honegger      Switzerland**

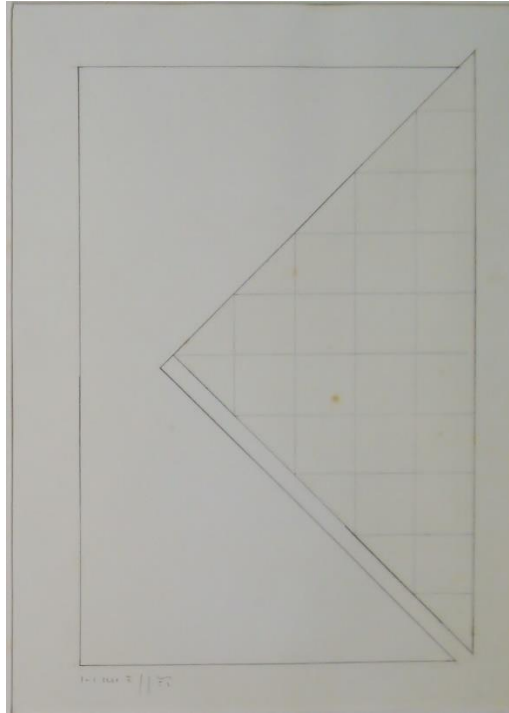

**Basic Info**

Name: Gottfried Honegger  
Profession: artist, curator  
Dates of life: 12<sup>th</sup> June 1917 – 17<sup>th</sup> January 2017, Zurich, Switzerland  
Country of Origin: Switzerland  
Lives:

Website: [www.gottfriedhonegger.ch/de/content/home/](http://www.gottfriedhonegger.ch/de/content/home/)

**Description work in PRO Drawing Collection**

Title: Étude 19, 1, 1987  
Materials: pencil, transparent paper collage on paper  
Sizes: H29.7 x W21 cm - c H11.7 x W8.3 inches  
Remarks: Honegger, a leading artist across Europe, was actively promoting concrete art, to that purpose he founded a foundation first in Zurich, Switzerland, later in Mouans-Sartoux, France; he was a close friend of the famous French minister for Culture Jacques Lang, who in 1997 involved Honegger in designing the Grande Arche de la Défense, Paris;  
Signed: title on reverse side; the work shows a small foxed spot bottom left

**Nr. 22**      **Vincenzo Arena**      **Italy**

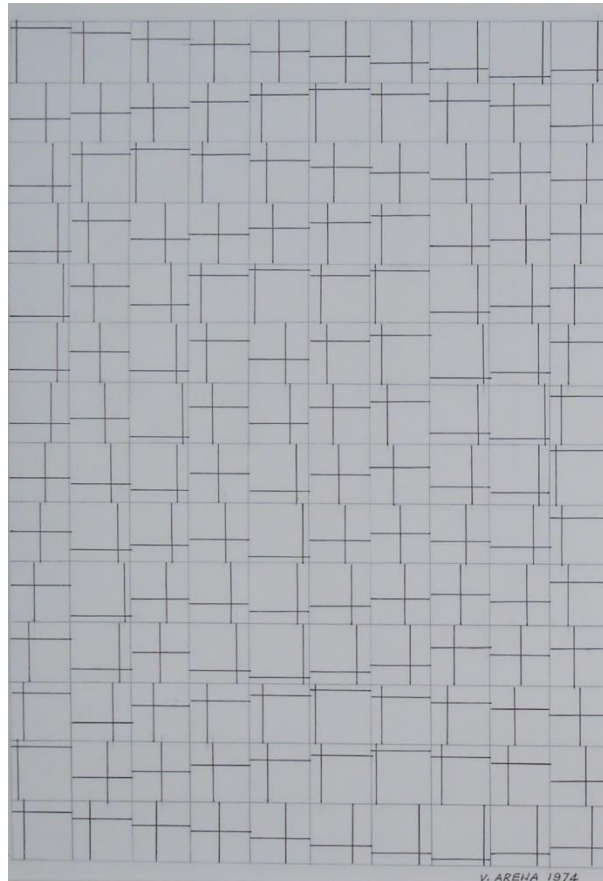

**Basic Info**

Name: Vincenzo Arena  
Profession: artist  
Dates of life: Palermo, 1932  
Country of Origin: Italy  
Lives: Rome and Paris  
  
Website: [vincenzoarena.com/mainframe-en.html](http://vincenzoarena.com/mainframe-en.html)

**Description work in PRO Drawing Collection**

Title: no title, 1974  
Materials: black and blue color pencil  
Sizes: H29.7 x W21 cm - c H11.7 x W8.3 inches  
Remarks: Vincenzo Arena was born in Italy, lives and works in Rome and Paris. He is a Co-founder of the CO.MO.(Constructivism and Movement) group in Paris, and worked with Michel Seuphor. Claiming to have been primarily influenced by Mondrian, Arena's career began by immersing himself in the world of repetitive lines and geometric abstraction. Arena has shown in exhibitions worldwide, including Austria, Belgium, Croatia, Ecuador, France, Germany, Italy, Poland, USA and Venezuela.

Signed: bottom right

**Nr. 23**

**Tim Johnson**

**UK**

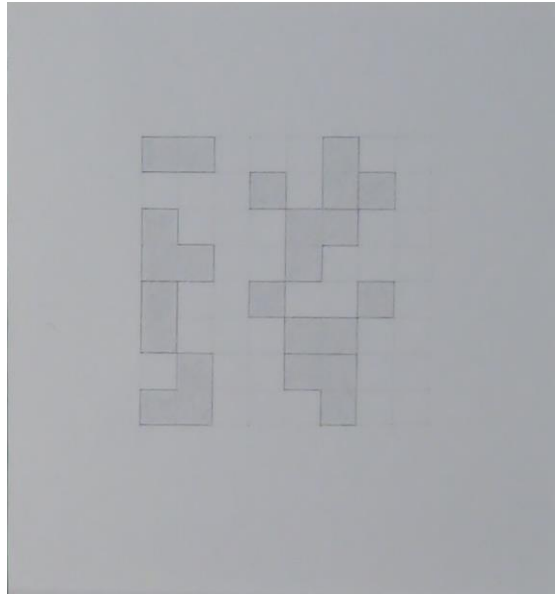

**Basic Info**

Name: Tim Johnson

Profession: artist

Dates of life:

Country of Origin: UK

Lives:

Website:

Description work in PRO Drawing Collection

Title: no title,

Materials: pencil

Sizes: H17 x W16 cm - H8¾ x W6¼ inches

Remarks:

Signed: on the reverse side

Nr. 24

Trevor Batten

UK/Netherlands

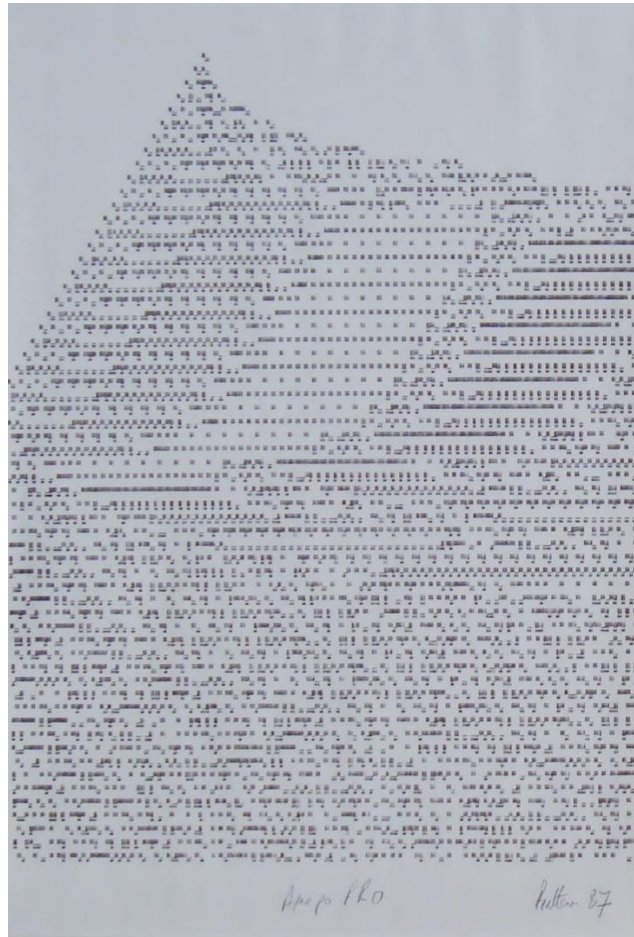

**Basic Info**

Name: Trevor Batten  
Profession: artist  
Dates of life: 1945, UK -  
Country of Origin: UK  
Lives: Amsterdam, the Netherlands  
Website: [www.tebatt.net/person.html](http://www.tebatt.net/person.html)

**Description work in PRO Drawing Collection**

Title: Apropo PRO, 1987  
Materials: computer print  
Sizes: H30 x W21 cm - H11¾ x W8¾ inches  
Remarks: inscribed on the reverse side in pencil "After po PRO"  
Signed: bottom right

**Nr.25 Catherine Pearson UK**

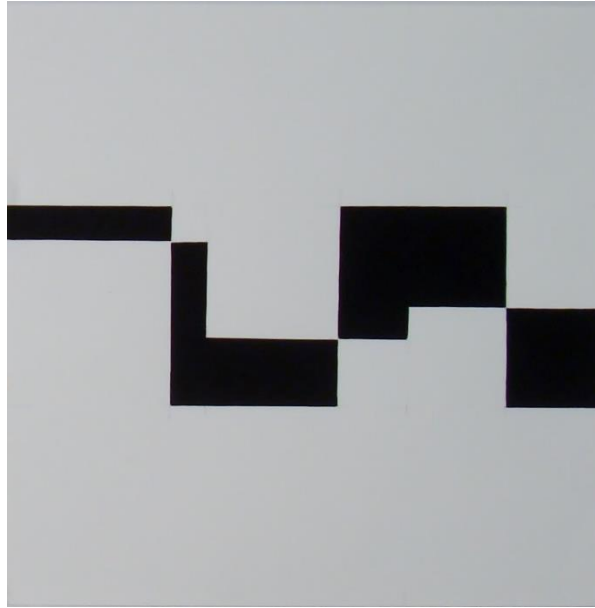

**Basic Info**

Name: Catherine Pearson

Profession: artist

Dates of life:

Country of Origin: UK

Lives:

Website:

Description work in PRO Drawing Collection

Title: 3part Constructed "Meanda" III

Materials: pencil and paint on paper

Sizes: 21 x 21 cm - 8¼ x 8¼ inches

Remarks: note on the reverse "Completed for PRO 1<sup>st</sup> Conference 1987"

Signed: on reverse

**Nr. 26**

**Klaus Staudt**

**W-Germany**

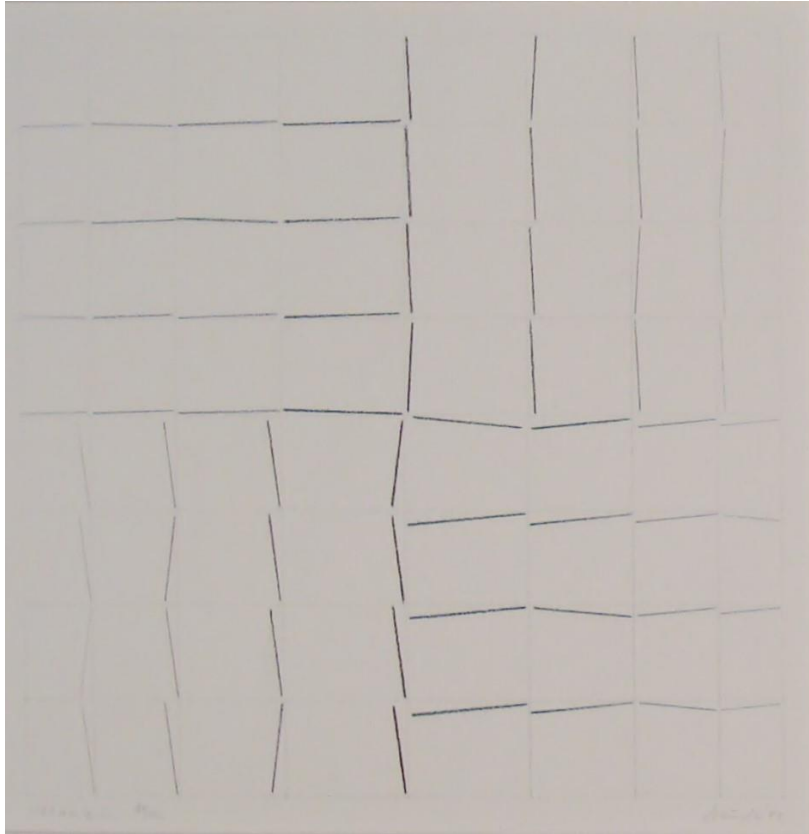

**Basic Info**

Name: Klaus Staudt  
Profession: artist  
Dates of life: 1932, Otterndorf -  
Country of Origin: Germany  
Lives: Frankfurt, Germany

Website: [www.klausstaudt.de/index\\_en.html](http://www.klausstaudt.de/index_en.html)

Description work in PRO Drawing Collection

Title: Sequenzen 21/120

Materials: pencil on paper

Sizes: H18 x W18 cm - c H7 x W7 inches

Remarks: Staudt is an accomplished artist of the generation of German artists since the 1960s, represented in many public and corporate collections throughout Germany and Switzerland, he was involved in GRAV (Group de Recherche d'Art Visuell), a group founded by Vera, Francois Molnar and some others in the 1960s.

Signed: bottom right

**Nr. 27**

**Dik Box**

**Netherlands**

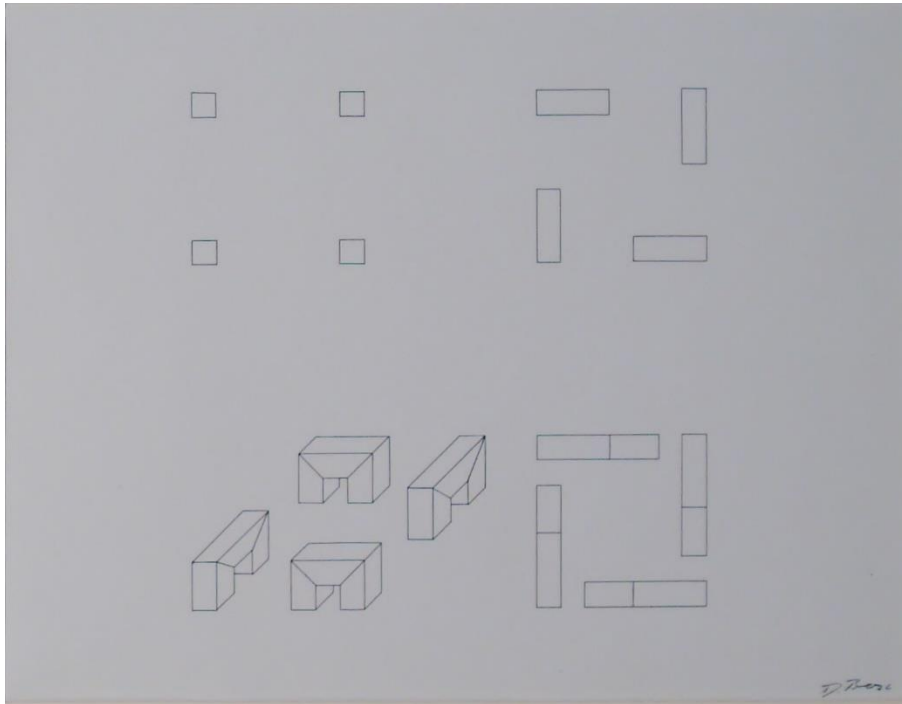

**Basic Info**

Name: Dik Box  
Profession: artist  
Dates of life: 1947 -  
Country of Origin: the Netherlands  
Lives:

Website:

Description work in PRO Drawing Collection

Title: no title  
Materials: ink on paper, glossy print  
Sizes: H20.5 x W29 cm - cH8 x W11½ inches  
Remarks: Box used to be known for his kinetic sculptures  
Signed: bottom right

**Nr. 28      Julian Gil      Spain**

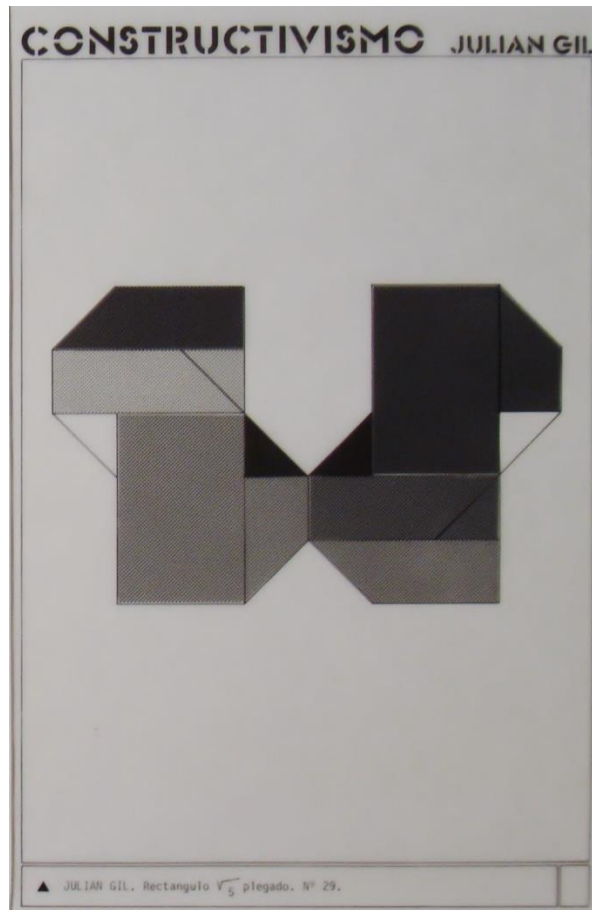

**Basic Info**

Name: Julian Gil  
Profession: artist  
Dates of life: 1939 -  
Country of Origin: Spain  
Lives:

Website: [www.rphart.net/en/artist/julian-gil](http://www.rphart.net/en/artist/julian-gil)

**Description work in PRO Drawing Collection**

Title: Constructivismo, Rectangulo V5 plegado No. 29  
Materials: ink and adhesive grids on paper  
Sizes: H29.7 x W21 cm - c H11.7 x W8.3 inches  
Remarks: Gil is one of the founders of a group of Spanish Constructivists  
Signed: bottom left

## Nr.29 Henri Prosi

## France



### Basic Info

Name: Henri Prosi  
Profession: artist  
Dates of life: 1936 - 2010  
Country of Origin: France  
Lives:

Website: [fr.wikipedia.org/wiki/Henri\\_Prosi](http://fr.wikipedia.org/wiki/Henri_Prosi)

Description work in PRO Drawing Collection

Title: 4 x 3 traversées, 1987  
Materials: paint and ink on paper  
Sizes: H29.7 x W21 cm - c H11.7 x W8.3 inches  
Remarks:  
Signed: on the reverse side

**Nr. 31 Waldo Balart**

**Cuba/Spain**

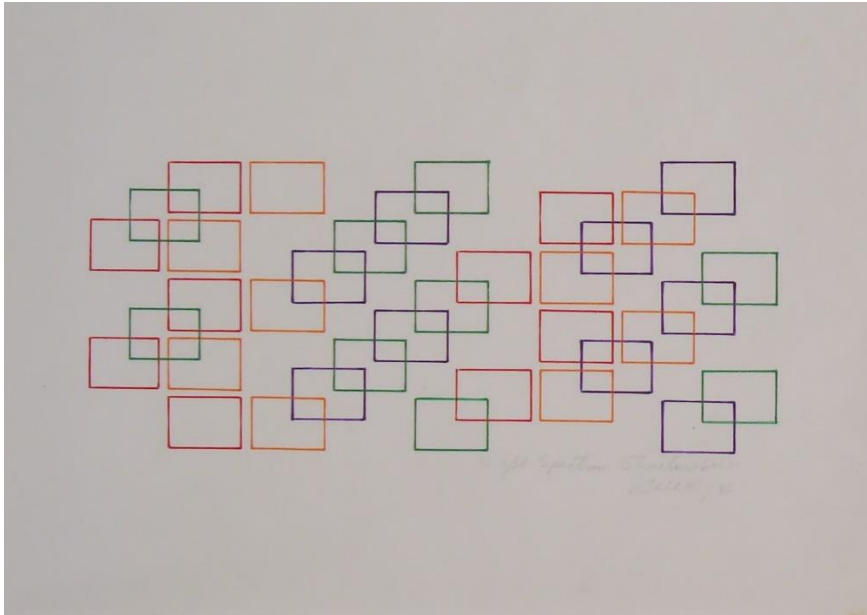

**Basic Info**

Name: Waldo Balart  
Profession: artist  
Dates of life: February 10<sup>th</sup> 1939 – February 5<sup>th</sup> 2025, Madrid, Spain  
Country of Origin: Cuba  
Lives:

Website: [waldobalart.com/](http://waldobalart.com/)

**Description work in PRO Drawing Collection**

Title: Light Spectrum Structure Series, 1986  
Materials: colored ink on paper  
Sizes: H21 x W29.7 cm - c H8.3 x W11.7 inches  
Remarks: Balart was one of the founders of a group of Spanish Constructivists  
Signed: bottom right

**Nr. 32**      **George Schade**      **Netherlands**

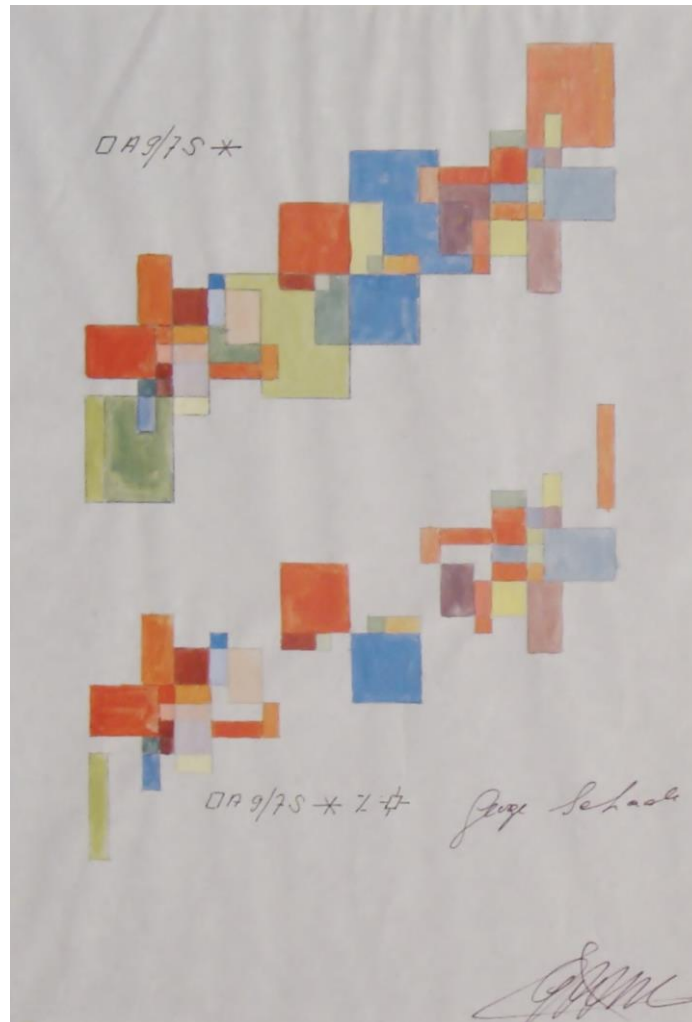

**Basic Info**

Name: George Schade  
Profession: artist  
Dates of life: 1945 -  
Country of Origin: the Netherlands  
Lives:

Website: [www.georgeschade.nl/studio](http://www.georgeschade.nl/studio)

Description work in PRO Drawing Collection

Title: DA9/7S\*ZO  
Materials: pencil and watercolor on paper  
Sizes: H29.7 x W21 cm - c H11.7 x W8.3 inches  
Remarks: thin paper wobbly caused by the watercolor  
Signed: bottom right

Nr. 33

Bart Huysman

Netherlands

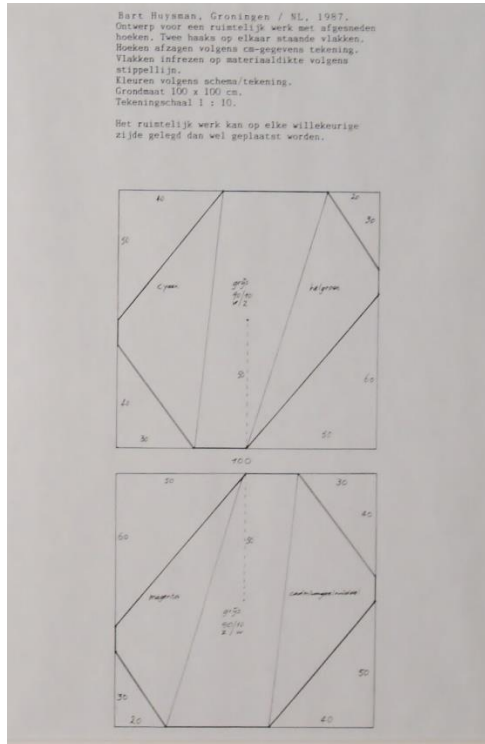

**Basic Info**

Name: Bart Huysman  
 Profession: artist  
 Dates of life: 1949 -  
 Country of Origin: the Netherlands  
 Lives:

Website: [www.bartartbox.nl/Bart-Huysman-Kunstenaar.html](http://www.bartartbox.nl/Bart-Huysman-Kunstenaar.html)

Description work in PRO Drawing Collection

Title: design for a sculpture  
 Materials: ink on paper  
 Sizes: H29.7 x W21 cm - c H11.7 x W8.3 inches  
 Remarks:  
 Signed: manually typed center top

**Nr. 34      Jos van de Ven      Netherlands**

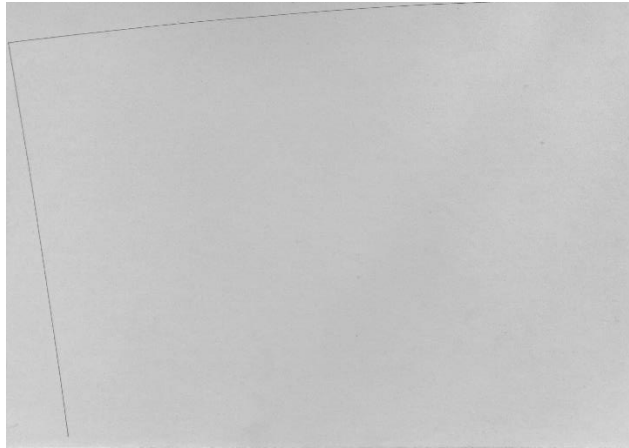

**Basic Info**

Name:                    Jos van de Ven  
Profession:             artist  
Dates of life:  
Country of Origin:     the Netherlands  
Lives:

Website:

Description work in PRO Drawing Collection

Title:                    no title, 1/10 1987  
Materials:              pencil on board  
Sizes:                    H21 x W29.7 cm - c H8.3 x W11.7 inches  
Remarks:              note on the reverse “na de tentoonstelling kan de tek. toegevoegd worden aan het Pro-archief”  
                                 (“after the exhibition the draw. can be added to the Pro-archive”)  
Signed:                    on the reverse side

**Nr. 35**      **Florin Granwehr**      **Switzerland**

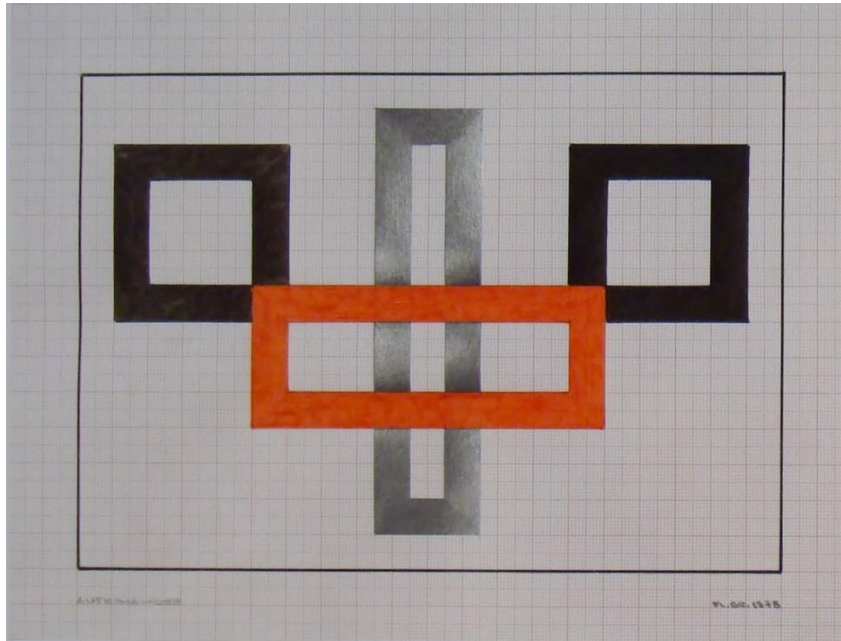

**Basic Info**

Name: Florin Granwehr  
Profession: artist  
Dates of life: 18<sup>th</sup> February 1942, St. Gallen – 23<sup>rd</sup> August 2019, Zurich, Switzerland  
Country of Origin: Switzerland  
Lives:

Website: [www.floringranwehr.com/](http://www.floringranwehr.com/)

Description work in PRO Drawing Collection

Title: Afeinander, 1975  
Materials: pencil and color on paper  
Sizes: H21 x W29.7 cm - c H8.3 x W11.7 inches  
Remarks:  
Signed: bottom right

**Nr. 36      Oskar Putz      Austria**



**Basic Info**

Name: Oskar Putz  
Profession: artist, designer  
Dates of life: 1940, Salzburg -  
Country of Origin: Austria  
Lives:  
  
Website: [de.wikipedia.org/wiki/Oskar\\_Putz\\_\(Maler\)](https://de.wikipedia.org/wiki/Oskar_Putz_(Maler))

**Description work in PRO Drawing Collection**

Title: 8614  
Materials: color pencil on paper  
Sizes: H29.7 x W21 cm - c H11.7 x W8.3 inches  
Remarks:  
Signed: on the reverse side

Nr. 37

David Geary

Canada

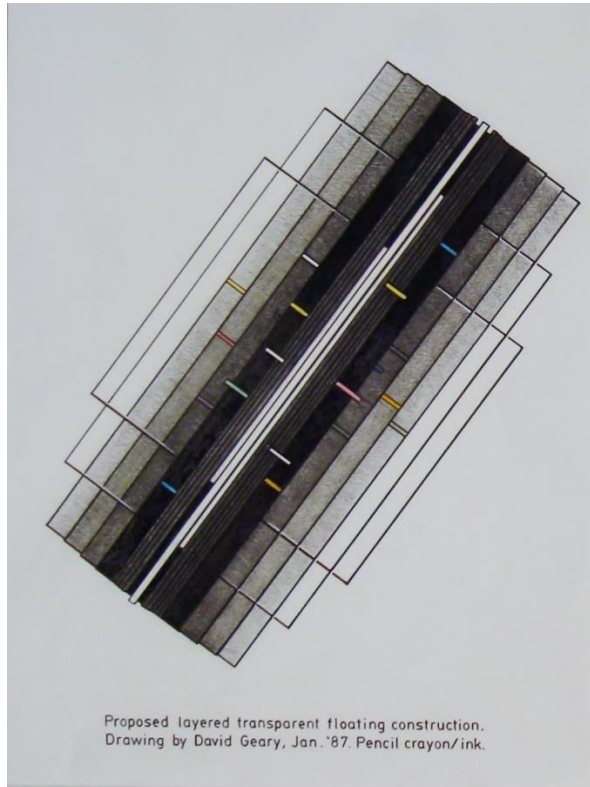

Proposed layered transparent floating construction.  
Drawing by David Geary, Jan. '87. Pencil crayon/ink.

**Basic Info**

Name: David Geary  
Profession: artist  
Dates of life: ?  
Country of Origin: Canada  
Lives:

Website: [harvest.usask.ca/server/api/core/bitstreams/48f7b988-e1ad-402c-9b0d-b39d62964af1/content](http://harvest.usask.ca/server/api/core/bitstreams/48f7b988-e1ad-402c-9b0d-b39d62964af1/content)  
This essay by Geary is the only reference to be found on the internet

**Description work in PRO Drawing Collection**

Title: Proposed layered transparent floating construction  
Materials: pencil, felt pen, ink on paper  
Sizes: H28 x W21.4 cm - H11 x W8 3/8 inches  
Remarks:  
Signed: on the lower front side in ink

**Nr. 38**

**Ad de Keyzer**

**Netherlands**

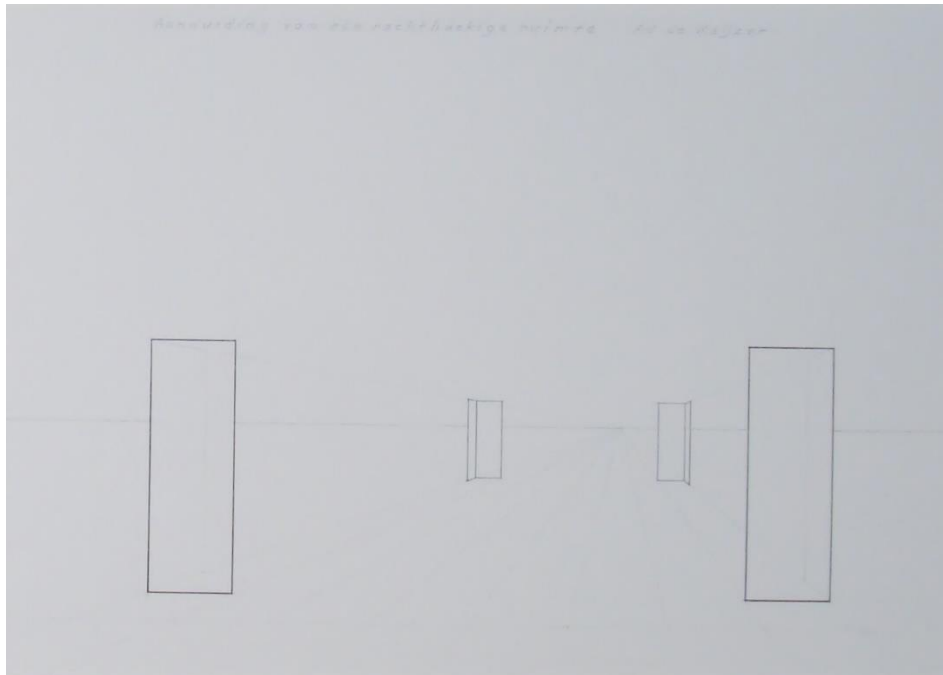

**Basic Info**

Name: Ad de Keyzer

Profession: artist

Dates of life: 1923, Arkel – 1997, Gorinchem, the Netherlands

Country of Origin: the Netherlands

Lives:

Website: [ftn-blog.com/2020/10/04/ad-de-keijzer-1923-1997/](https://ftn-blog.com/2020/10/04/ad-de-keijzer-1923-1997/)

Description work in PRO Drawing Collection

Title: Aanduiding van een rechthoekige ruimte (indication for a rectangular space)

Materials: pencil on paper

Sizes: H21 x W29.7 cm - c H8.3 x W11.7 inches

Remarks:

Signed: bottom right

**Nr. 39**      **Walter Leblanc**      **Belgium**

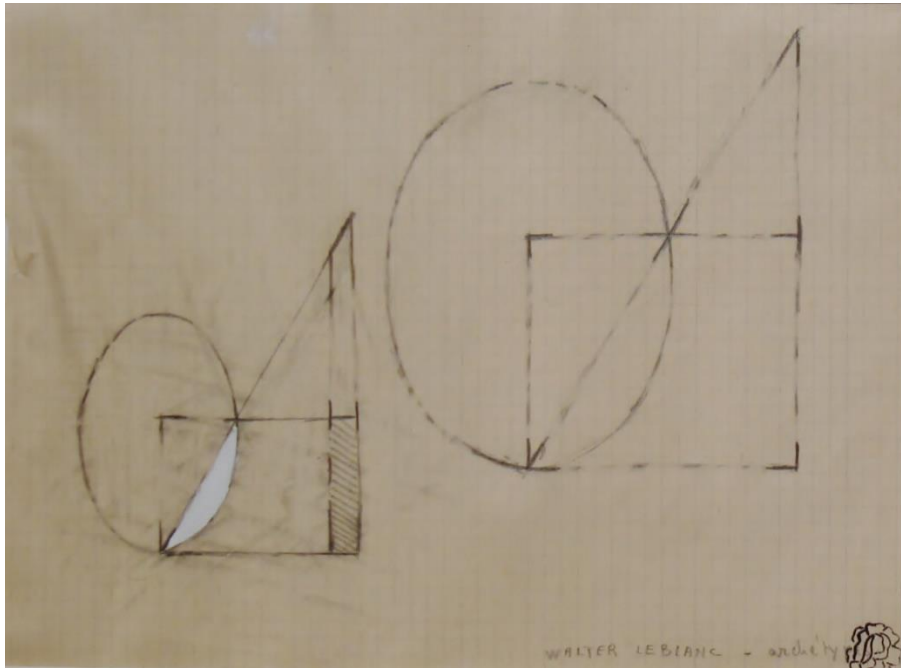

**Basic Info**

Name: Walter Leblanc  
Profession: artist  
Dates of life: 26<sup>th</sup> December 1932, Antwerpen – January 14<sup>th</sup>, 1986, Silly, Belgium  
Country of Origin: Belgium  
Lives:

Website: [www.walterleblanc.org](http://www.walterleblanc.org)

**Description work in PRO Drawing Collection**

Title: Archetype, c 1975  
Materials: pencil and gouache on paper  
Sizes: H21 x W29.7 cm - c H8.3 x W11.7 inches  
Remarks: Leblanc is internationally very well known, he was a member of the originally German Zero-Group (the European equivalent to American Minimalism); his works are in many prominent collections like the Tate Gallery, London, who own a painting with a similar composition.  
Signed: bottom right

**Nr. 41**      **Opy Zouni**      **Greece**



**Basic Info**

Name: Opy Zouni  
Profession: artist  
Dates of life: February 1941, Cairo, Egypt – 5<sup>th</sup> December 2008, Athens, Greece  
Country of Origin: Greece  
Lives:

Website: [www.zouni.gr/opy\\_zouni.html](http://www.zouni.gr/opy_zouni.html)

Description work in PRO Drawing Collection

Title: no title, 1987  
Materials: grey board relief, cut-out and paint  
Sizes: H21 x W29.7 cm - c H8.3 x W11.7 inches  
Remarks:  
Signed: bottom left and on the reverse

**Nr. 42**

**Helmut Bruch**

**Austria**



**Basic Info**

Name: Helmut Bruch  
Profession: artist  
Dates of life: 1<sup>st</sup> June 1936, Hall, Tirol, Austria –  
Country of Origin: Austria  
Lives:

Website: <https://www.hellmutbruch.com/sites/bio.html>

Description work in PRO Drawing Collection

Title: Radius 86 cm  
Materials: acrylic paint on aluminum sheet with curved line inscribed  
Sizes: H29.7 x W21 cm - c H11.7 x W8.3 inches  
Remarks:  
Signed: on the reverse side, with note: “Die Arbeit kann in das PRO Archiv aufgenommen werden“  
„The work can be included in the PRO Archives”

**Nr. 43      Yves Popet      France**

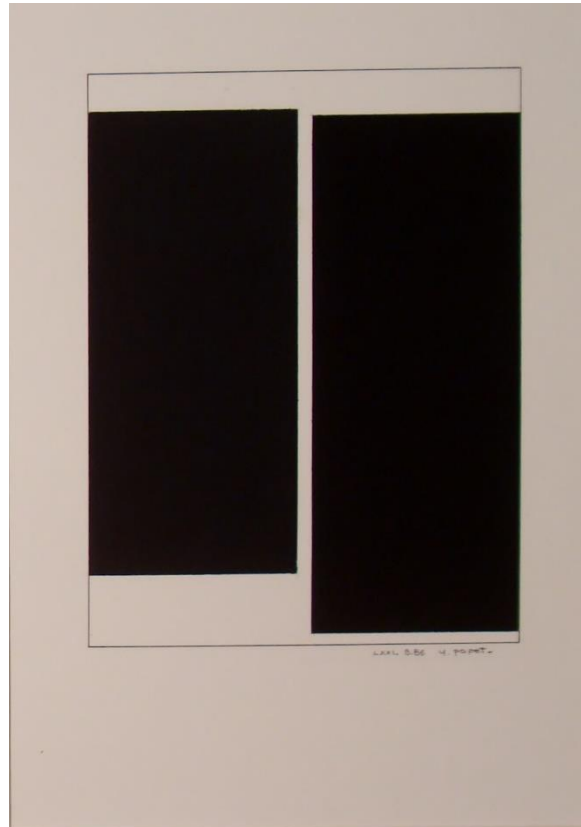

**Basic Info**

Name: Yves Popet  
Profession: artist  
Dates of life: 15<sup>th</sup> August 1946, Reims, France -  
Country of Origin: France  
Lives: Paris, France

Website: [www.yvespopet.com/](http://www.yvespopet.com/)

Description work in PRO Drawing Collection

Title: LXXL B86, 1986  
Materials: pencil and ink on paper  
Sizes: H29.7 x W21 cm - c H11.7 x W8.3 inches  
Remarks: an additional work is on next page  
Signed: bottom right

**(no number – extra) Yves Popet France**

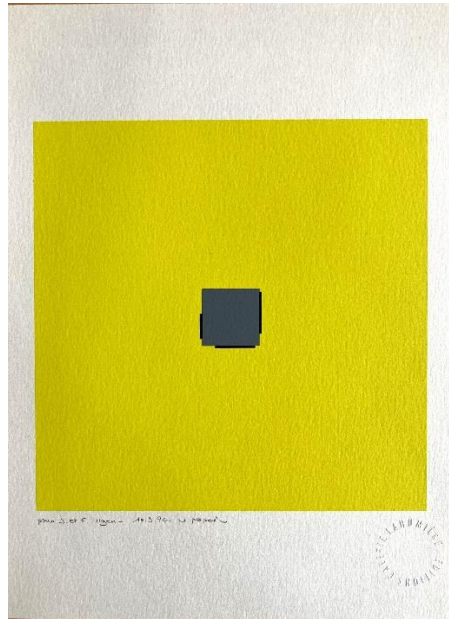

**Basic Info**

Name: Yves Popet  
Profession: artist  
Dates of life: 15<sup>th</sup> August 1946, Reims, France -  
Country of Origin: France  
Lives: Paris, France

Website: [www.yvespopet.com/](http://www.yvespopet.com/)

Description work in PRO Drawing Collection

Title: 10.3 94, Edition Lahumière  
Materials: screenprint  
Sizes: H27.5 x W20.2 cm - H10¾ x W8 inches  
Remarks: inscribed in pencil under the image:  
"Pour J. et F. Ilgen" („For J. and F. Ilgen")  
Signed: bottom left

**Nr. 44      José Maria Iglesias      Spain**

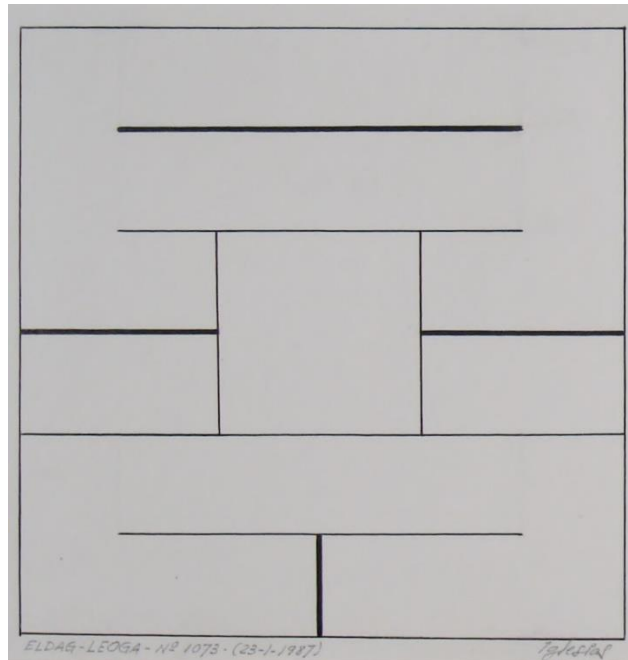

**Basic Info**

Name: José Maria Iglesias

Profession: artist

Dates of life: 1933 - 2005

Country of Origin: Spain

Lives:

Website: [www.ozpod.com/gallery/artists/igle.html](http://www.ozpod.com/gallery/artists/igle.html)

Description work in PRO Drawing Collection

Title: Eldag – Leoga – No 1073, 1987

Materials: pencil, ink on paper

Sizes: H20 x W20 cm - cH8 x W8 inches

Remarks: Iglesias was one of the founders of a group of Spanish Constructivists

Signed: bottom right

**Nr. 45**      **Wolfgang Döring**      **W-Germany**

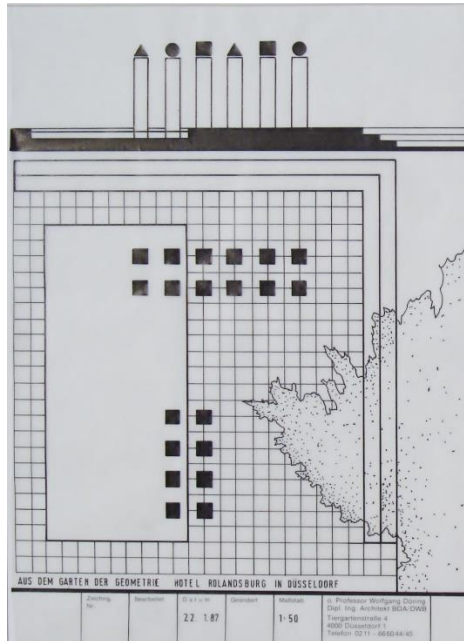

**Basic Info**

Name: Wolfgang Döring  
 Profession: artist, architect  
 Dates of life: 1934, Berlin-Dahlem – 4<sup>th</sup> November 2020, Düsseldorf, Germany  
 Country of Origin: Germany  
 Lives:

Website: [www.ddj.de/buero/wolfgang-doering/](http://www.ddj.de/buero/wolfgang-doering/)

**Description work in PRO Drawing Collection**

Title: Aus dem Garten der Geometrie, (From the Garden of Geometry), design for a sculpture  
 Materials: ink on paper  
 Sizes: H29.7 x W21 cm - c H11.7 x W8.3 inches  
 Remarks:  
 Signed: bottom right

**Nr. 46**

**Charles Bézie**

**France**

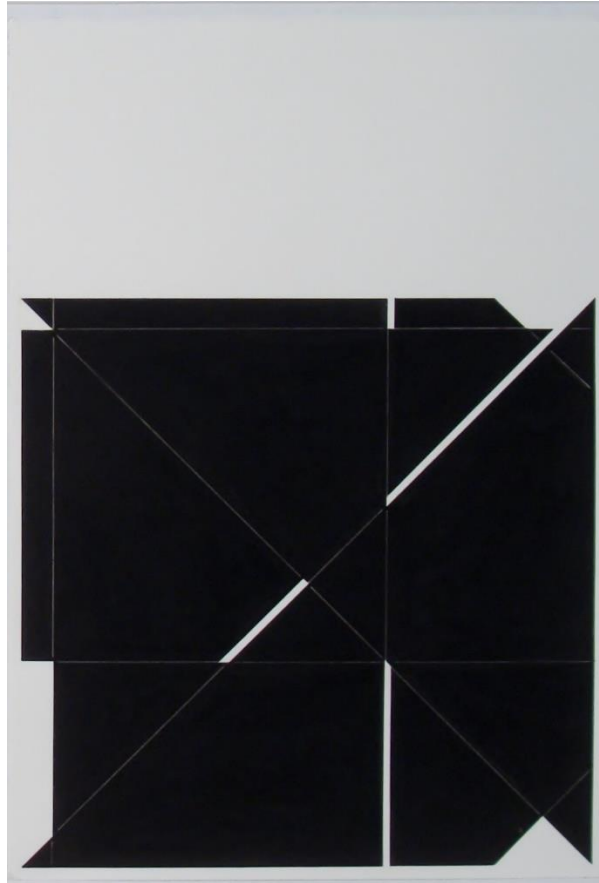

**Basic Info**

Name: Charles Bézie  
Profession: artist  
Dates of life: 1934, Varade, France -  
Country of Origin: France  
Lives:

Website: [www.lahumiere.com/artistes-v3/charles-bzie](http://www.lahumiere.com/artistes-v3/charles-bzie)

**Description work in PRO Drawing Collection**

Title: no title  
Materials: pencil and ink on paper  
Sizes: H30.3 x W21 cm - H12 x W8¼ inches  
Remarks:  
Signed: on the reverse

**Nr. 47      Jean-Pierre Maury      Belgium**

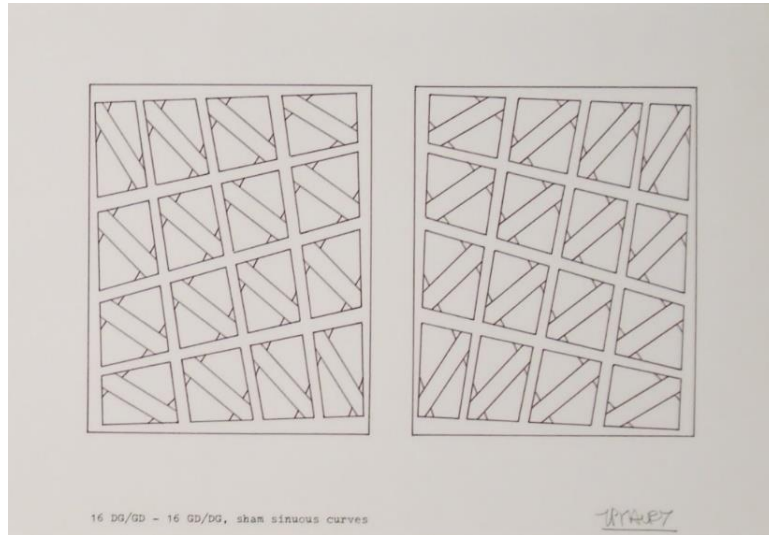

**Basic Info**

Name: Jean-Pierre Maury  
Profession: artist  
Dates of life: 1948, Belgium -  
Country of Origin: Belgium  
Lives:

Website: [jean-pierre-maury.com/](http://jean-pierre-maury.com/)

**Description work in PRO Drawing Collection**

Title: 16 DG/GD – 16 GD/DG, sham sinuous curves, 1987

Materials: ink on paper

Sizes: H21 x W29.7 cm - c H8.3 x W11.7 inches

Remarks: Maury has actively promoted constructive art and is one of the founders of the artist magazine *Mésures-Art International*, his works are in many collections, mainly in Belgium, France, Germany; for many activities of the PRO Foundation there was a close collaboration with Maury, like realizing large group exhibitions in museums in various cities in Belgium;

Signed: bottom right

**(no number – extra) Jean-Pierre Maury Belgium**

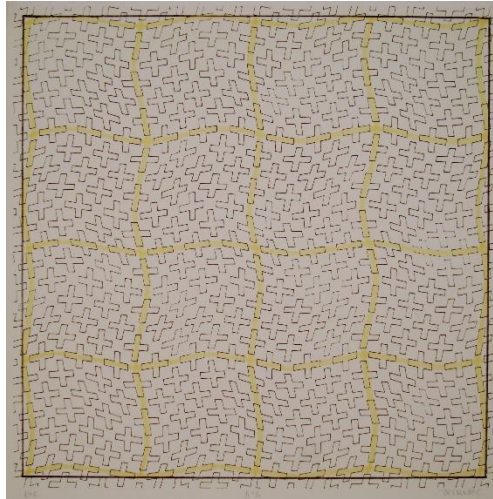

**Basic Info**

Name: Jean-Pierre Maury  
Profession: artist  
Dates of life: 1948, Belgium -  
Country of Origin: Belgium  
Lives:

Website: [jean-pierre-maury.com/](http://jean-pierre-maury.com/)

**Description work in PRO Drawing Collection**

Title: No 6  
Materials: ink and felt pen on paper  
Sizes: cH20 ½ x W20½ cm - H8 1/8 x W8 1/8 inches  
Remarks: Maury has actively promoted constructive art and is one of the founders of the artist magazine Mésures-Art International, his works are in many collections, mainly in Belgium, France, Germany; for many activities of the PRO Foundation there was a close collaboration with Maury, like realizing large group exhibitions in museums in various cities in Belgium;  
Signed: bottom right

Nr. 49

Vera Röhm

W-Germany

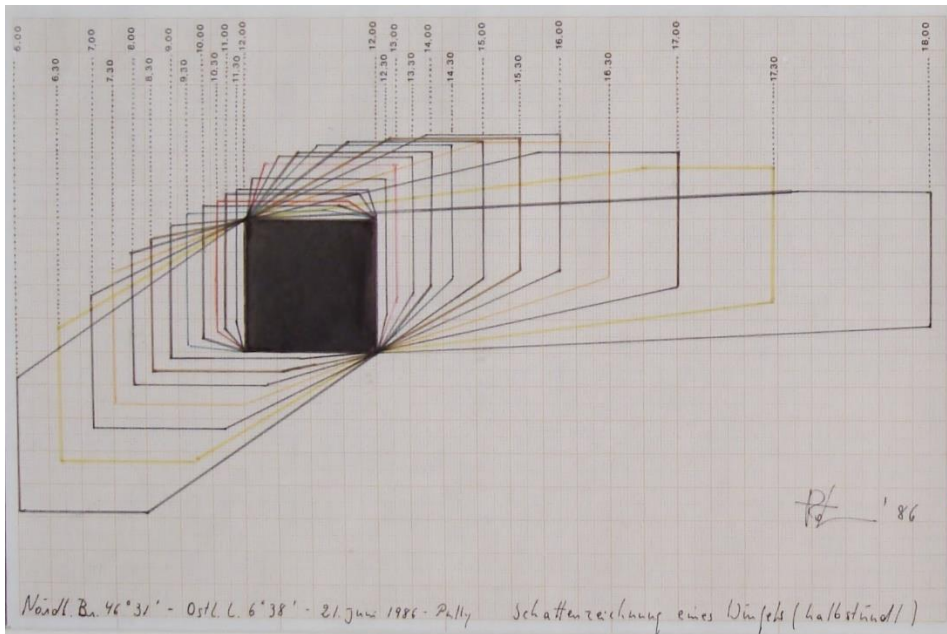

#### Basic Info

Name: Vera Röhm  
Profession: artist  
Dates of life: 1943, Landsberg am Lech, Germany -  
Country of Origin: Germany  
Lives:

Website: [veraroehm.com/de](http://veraroehm.com/de)

Description work in PRO Drawing Collection

Title: Schattenzeichnung eines Würfels (halbstünd) – (Shadow drawing of a cube (half hourly))  
Materials: ink, felt pen on paper  
Sizes: H19 x W29.7 cm - H7½ x W11.7 inches  
Remarks: Röhm is known for her often large sculptures using plexiglass  
Signed: bottom right